

Seapoint Turbidity Meter

User Manual



Standard Version

*with Custom Gain:
5x normal gain*

Dimensions

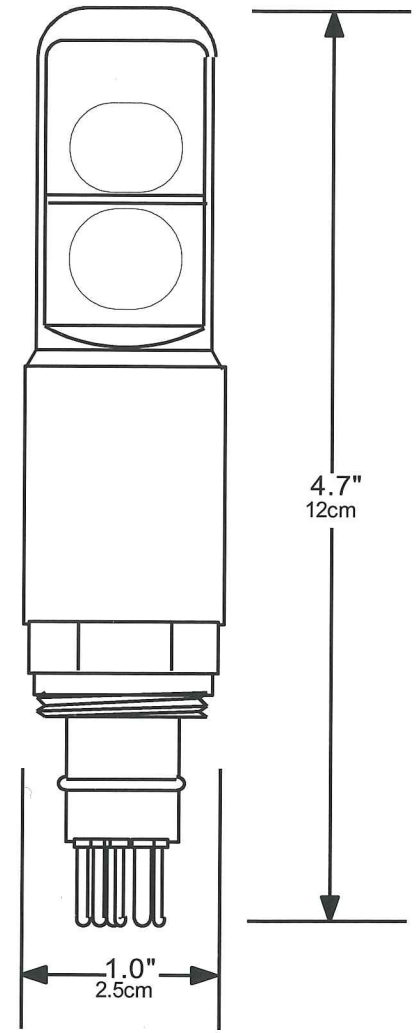

Figure 1. Outline Drawing

Specifications

Power Requirements: 7-20VDC, 11mA avg, 21mA pk

Output: 0-5.0 VDC

Output Time Constant: 0.1 sec

RMS Noise: <1 mV

Power-up Transient Period: <1 sec

Light Source Wavelength: 880 nm

Scatterance Angles: 15 - 150 degrees

Linearity: <2% deviation 0-750 FTU

Sensitivity/Range:

100x gain:	1000 mV/FTU	5 FTU
20x gain:	200 mV/FTU	25 FTU
5x gain:	50 mV/FTU	100 FTU
1x gain:	10 mV/FTU	500 FTU

Temperature Coefficient: <0.05 %/°C

Operating Temperature: 0°C to 65°C

Depth Capability: 6000 m (19,700 ft)

Overall Length: 12 cm (4.7 in)

Sensor Weight (dry): 86 g (3.0 oz)

Body Diameter: 2.5 cm (1.0 in)

Introduction

The Seapoint Turbidity Meter is a sensor that measures turbidity by detecting scattered light from suspended particles in water. Its small size, very low power consumption, high sensitivity, wide dynamic range, and 6000 meter depth capability allow this sensor to be used in most applications where turbidity or suspended particle concentrations are to be measured. The sensor is also insensitive to ambient light when under water and has a very low temperature coefficient.

The Seapoint Turbidity Meter senses scattered light from a small volume within 5 centimeters of the sensor windows. Confining the sensing volume allows the sensor to be calibrated in relatively small water containers without errors from surface and wall reflections. It also allows the sensor to be used in tight spaces such as crowded instrumentation packages, pipes, and shallow streams.

Two control lines allow the user to externally set the sensitivity of the Seapoint Turbidity Meter by choosing one of four gains. This provides an easy means to set the sensitivity to provide the range and resolution required for a particular application. Sensitivities of 10, 50, 200 and 1000 mV/FTU are possible.

Each sensor is factory adjusted for consistent response to Formazin Turbidity Standard measured in Formazin Turbidity Units (FTU). The user may also calibrate the sensor with particles of interest to measure their suspended concentrations.

The Seapoint Turbidity Meter is constructed of rugged, corrosion resistant materials and quality surface mount electronic components for durability and high reliability.

Optical Design

Figure 2 shows a cross-section of the Seapoint Turbidity Meter optics.

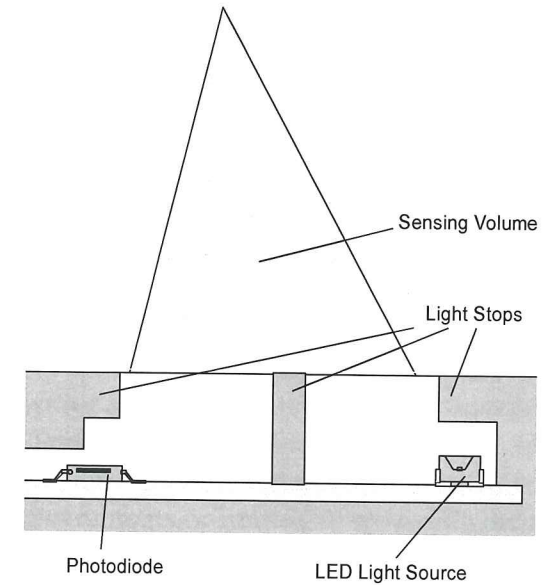

Figure 2. Diagram of Seapoint Turbidity Meter Optics

The light sources are side by side 880 nm Light Emitting Diodes. The light detectors are side by side silicon photodiodes with visible light blocking filters. The light sources are extremely efficient and well matched to the peak sensitivity of the silicon photodiodes. The opaque housing forms a light block which prevents light from the emitter from reaching the detector directly. Light from the LEDs shines through the clear epoxy emitter window into the sensing volume where it is scattered by particles. It is possible for light scattered at angles between 15 and 150 degrees to pass through the detector window and reach the

detector. The amount of scattered light that reaches the detector is proportional to the turbidity or particle concentration in the water over a very large range.

The optical design of the Seapoint Turbidity Meter is unique in its restriction of the angle of emission of the light sources and the angle of detection of the light detectors. This confines the sensing volume to within five centimeters of the sensor windows. The advantage to confining the sensing volume to a small space near the sensor is the great reduction of interference from reflections from large objects outside the sensing volume. This allows the sensor to be calibrated in a relatively small water container without interference from surface or wall reflections. It also allows the sensor to be used where limited volumes of water exist for sensing or in the midst of objects which would otherwise cause interfering reflections. Examples include instrumentation packages with limited space between instruments or limited space inside the frame, monitoring water inside pipes, and measuring water in shallow streams or near stream beds.

Electronic Design

The Seapoint Turbidity Meter has an electronic design that achieves high sensitivity while consuming very little power. Surface mount components are used for high reliability and compact design. Low quiescent current components are used so that most of the power drawn by the sensor is used to drive the light source. Overall power requirements are 7-20 VDC, 11 mA average, 21 mA peak.

Optical feedback is incorporated in the light source drive circuitry. This offers several benefits including excellent temperature compensation for the optical components, compensation for the aging of the optical components, and stable output within a second after power up.

The light source is modulated and synchronous detection is used to extract the scatterance signal from the unwanted portion of the signal resulting from ambient light and electronic noise. Achieving high sensitivity using low power was accomplished by paying careful attention to proper circuit board layout to prevent any stray coupling of signals synchronous with the modulation of the light source into the detection circuitry. The need for offset adjustment was thereby eliminated — the offset voltage for this sensor at any gain is within one millivolt of zero.

Operation

The Seapoint Turbidity Meter requires 7 to 20 VDC input and will draw an average of 11 mA current with a peak current draw of 21 mA. Output is 0 to 5.0 VDC with a 0.1 second time constant.

Warning: Applying voltages to the output pin or powering the sensor with a voltage greater than 20 V will result in damage to the sensor.

The Impulse AG-306 bulkhead (connector end of sensor) and the mating AG-206 connector (included with pigtail) should be cleaned and lubricated with 3M Silicone Spray, Dow Corning #111 Valve Lubricant or equivalent prior to connecting.

The pin numbering on the AG-306 is shown in Figure 3. Note that Pin 1 is larger than the other pins. The AG-206 connector has two raised bumps which align with Pin 1 to make connection with the AG-306 easy. The AG-206 pigtail is supplied with a locking sleeve which screws onto the AG-306 connector after the pigtail is plugged in.

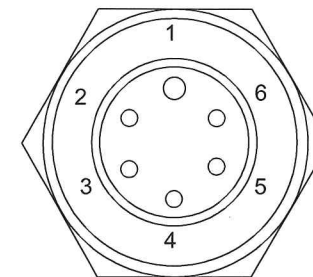

Figure 3. AG-306 Pin Numbering

Connections for the Impulse AG-206/306 are as follows:

Pin 1	white:	Power Ground
Pin 2	black:	Signal Output
Pin 3	blue:	Signal Ground
Pin 4	orange:	Power In
Pin 5	green:	Gain Control A
Pin 6	red:	Gain Control B

The two independent gain control lines A and B are used to select one of four possible gain settings (see Table 1).

These wires can be hardwired for the desired gain or interfaced with a microprocessor, using 5 volt logic, to allow gain to be controlled through software. Hardwiring the gain does not require an external voltage source. To hardwire a line to +5V, simply leave it open, which allows an internal pull-up to hold it at +5 VDC. To set a line to 0V, tie it to the power ground.

<u>A</u>	<u>B</u>	<u>Gain</u>	<u>Sensitivity</u>	<u>Range</u>
+5 V	+5 V	100X	1000 mV/FTU	5 FTU
+5 V	0 V	20X	200 mV/FTU	25 FTU
0 V	+5 V	5X	50 mV/FTU	100 FTU
0 V	0 V	1X	10 mV/FTU	500 FTU

Table 1. Truth Table for Switching Gains

The sensor has a linearity in Formazin of $\pm 2\%$ at all gain settings. The 1X gain setting is provided for extremely turbid water. Figure 4 shows a typical sensor response.

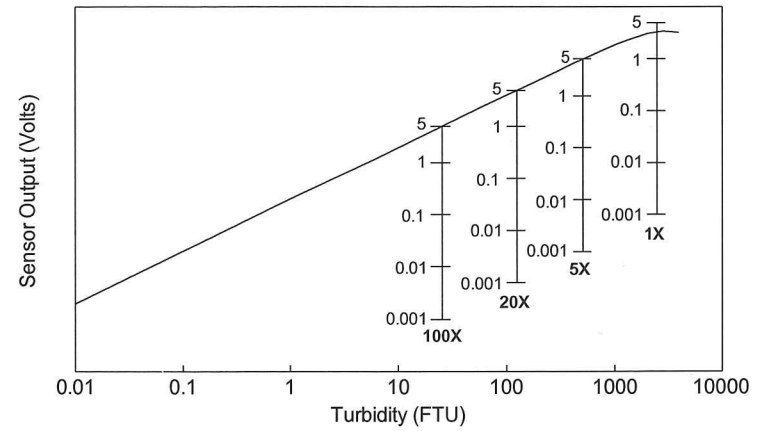

Figure 4. Sensor Response to Formazin Turbidity Standard

Calibration

All sensors are adjusted to the nominal sensitivities specified so that for most purposes they are interchangeable. If greater accuracy is desired, it is recommended that the user perform calibrations on individual sensors.

The sensors can also be calibrated by the user to measure suspended particle concentrations. Like all optical instruments, this calibration must be performed using a sample from the measurement site. Calibrations with different particle types will typically yield erroneous results.

Calibrations should be performed periodically at a frequency which depends on the condition of the windows. Although these sensors are electronically stable with time, scratching or fouling of the windows will result in reduced sensitivity. Visual inspection is a good test of whether the sensor needs recalibration: if the windows appear polished and clear when dry, the sensitivity probably has not changed significantly.

When calibrating in a small container, multiple scattering events may reflect off the container walls introducing a small error to the calibration. For this reason, the use of a black container is recommended.

Calibration should be performed under fluorescent lighting. Incandescent lights emit large amounts of energy at the operating wavelength which may interfere with measurements.

Care

The Seapoint Turbidity Meter is a rugged instrument that should provide years of reliable performance with minimal care.

After using, rinse the sensors and clean the windows with water and mild detergent if necessary (avoid using organic solvents). If windows become scratched, they may be polished using a cloth buffing wheel with polishing compound.

The connectors should be lubricated before each use with 3M silicone Spray, Dow Corning #111 Valve Lubricant or equivalent.

The Seapoint Turbidity Meter contains no user serviceable electronics and must be returned to the factory if it does not operate properly.

Limited Warranty

Seapoint Sensors, Inc. warrants this Turbidity Meter to be free of defects of materials and workmanship under normal use and service for a period of 1 year from the date of shipment. This warranty extends only to the original purchaser.

In the event the product fails to operate according to our published specifications during the warranty period, Seapoint Sensors, Inc. will repair or replace the instrument at our discretion. If it is determined that the failure was due to other than normal use or service, repairs will be billed and estimate will be submitted prior to repair work.

Shipping costs must be prepaid. Seapoint Sensors, Inc. accepts no responsibility for damage during return shipment.